

### SWAGING TOOLS

Use these tools for expand one end of soft and half-hard copper, soft aluminum, brass, soft steel... for connecting same size tubes and solder without fittings. To use together with the Clamping Bars (Metric or inch version) and a hammer.

- Heat-treated and plated alloy steel.

OUTSIDE TUBE DIAMETER / MAX WALL THICKNESS " / mm.									
3/16"	1/4"	5/16"	3/8"	7/16"	1/2"	5/8"	3/4"	7/8"	
0,028"	0,035"	0,035"	0,035"	0,035"	0,035"	0,035"	0,035"	0,045"	
4 mm.	6 mm.	8 mm.	10 mm.	12 mm.	14 mm.	16 mm.	18 mm.	22 mm.	
0,7 mm.	0,9 mm.	0,9 mm.	0,9 mm.	0,9 mm.	0,9 mm.	0,9 mm.	0,9 mm.	1,1 mm.	

### 5-IN-ONE SWAGING TOOLS

- Hex design for ease of extraction.



Model	Description
SPT01	5-in-1 Swaging Punch for Ø 1/4", 5/16", 3/8", 1/2" & 5/8" O.D. tubing.
SPT01MM	Ø 8, 10, 12, 14 and 16 mm. O.D. tubing.

### 3-IN-ONE SWAGING TOOLS



Model	Description
SPT 81012	3-IN-1 Swaging tool for Ø 1/2", 5/8" and 7/8" O.D. tubing.
SPT121622MM	Ø 12, 16 and 22 mm. O.D. tubing.

### MULTISWAGE PUNCH TOOLS

Enlarge end of tube even when near a elbow.

- Four pieces, threaded between them;
- Hex design for ease of extraction.



Model	Description
SPT00	Multiswage Punch Tool for Ø 3/16", 1/4", 5/16", 3/8", 7/16", 1/2", 5/8", 3/4" e 7/8" O.D. tubing.
SPT00MM	Ø 4, 6, 8, 10, 12, 14, 16, 18 e 22 mm. O.D. tubing.

### SINGLE SIZE SWAGING TOOLS

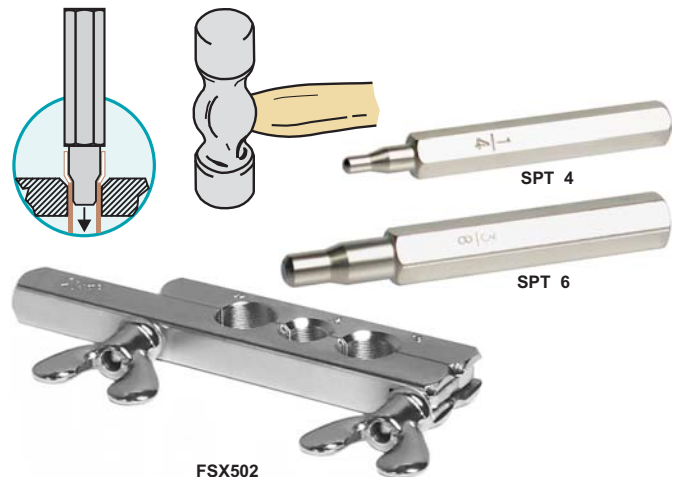

Model	Description
SPT 2	Swaging tool for Ø 1/8" O.D. tubing
SPT 3	Ø 3/16" O.D. tubing.
SPT 4	Ø 1/4" O.D. tubing.
SPT 5	Ø 5/16" (8 mm.) O.D. tubing.
SPT 6	Ø 3/8" O.D. tubing.
SPT 7	Ø 7/16" O.D. tubing.
SPT 8	Ø 1/2" O.D. tubing.
SPT10	Ø 5/8" OD. tubing.
SPT12	Ø 3/4" O.D. tubing.
SPT14	Ø 7/8" O.D. tubing.
SPT18	Ø 1-1/8" O.D. tubing.
SPT02	Set of 4 swaging punches tools for 1/4", 3/8", 1/2" and 5/8" O.D. tubing.
SPT03	Set of 5 for 1/4", 5/16", 3/8", 1/2" and 5/8" O.D. tubing
SPT04MM	Swaging tool for Ø 4 mm. O.D. tubing.
SPT06MM	Ø 6 mm. O.D. tubing.
SPT08MM	Ø 8 mm. O.D. tubing.
SPT10MM	Ø 10 mm. O.D. tubing.
SPT12MM	Ø 12 mm. O.D. tubing.
SPT14MM	Ø 14 mm. O.D. tubing.
SPT15MM	Ø 15 mm. O.D. tubing.
SPT16MM	Ø 16 mm. O.D. tubing.
SPT18MM	Ø 18 mm. O.D. tubing.
SPT22MM	Ø 22 mm. O.D. tubing.
SPT28MM	Ø 28 mm. O.D. tubing.
SPT02MM	Set of 4 swaging punches tools for 6, 10, 12 and 16 mm. O.D. tubing.
SPT03MM	Set of 5 for 6, 8, 10, 12 and 16 mm. O.D. tubing.
Accessories	
FSX501	Clamping Bar for Ø 1/8", 3/16", 1/4", 5/16", 3/8", 7/16" O.D. tubing.
FSX502	Ø 1/2", 5/8" and 3/4" O.D. tubing.
FTX525	Ø 5/8", 3/4", 7/8" and 1-1/8" O.D. tubing.
FSX511	Ø 4, 6, 8, 10, 12, 15 and 16 mm. O.D. tubing
FSX512	Ø 14, 18 and 22 mm. O.D. tubing

### LEVER TYPE TUBE EXPANDERS

For soft and half-hard copper, brass, soft aluminum and soft steel tubing - Maximum wall thickness 0,06" (1,6 mm). Studied for an easy expansion of the tubing ends in order to have a fitting-free tube installation. Re-rounds deformed tubing.

- Steel forged body;
- Longer lever arms, ergonomic handles reducing effort and increasing work space, safer handling;
- Steel expander heads to correct distorted tubing with diameter identification on for an easy recognition;
- Metal Carrying Case for long-term protection.

These Expander Heads fit other Lever Tube Expanders from different brands (Ridgid, Rothenberger...).



Model	Description
TLE6	Tube Expander Set with Head for Ø 3/8", 1/2", 5/8", 3/4", 7/8", 1" O.D. tubing. Metal case.
TLE6MM	Ø 10, 12, 15, 16, 18, 22 mm. O.D. tubing. Metal Case.
<b>Spare Parts</b>	
TLE601	Tube Expander - Body only.
TEH 6	Head for tube expander Ø 3/8" O.D. tubing.
TEH 8	Ø 1/2" O.D. tubing.
TEH10	Ø 5/8" O.D. tubing.
TEH12	Ø 3/4" O.D. tubing.
TEH14	Ø 7/8" O.D. tubing.
TEH16	Ø 1" O.D. tubing.
TEH18	Ø 1-1/8" (28 mm.) O.D. tubing.
TEH22	Ø 1-3/8" (35 mm.) O.D. tubing.
TEH26	Ø 1-5/8" (42 mm.) O.D. tubing.
TEH10MM	Head for tube expander Ø 10 mm. O.D. tubing.
TEH12MM	Ø 12 mm. O.D. tubing.
TEH15MM	Ø 15 mm. O.D. tubing.
TEH16MM	Ø 16 mm. O.D. tubing.
TEH18MM	Ø 18 mm. O.D. tubing.
TEH22MM	Ø 22 mm. O.D. tubing.
TLE6MB	Metal Case for TLE6 and TLE6MM.

### HYDRAULIC TUBE EXPANDER KITS

For soft and half-hard copper, brass, soft aluminum and soft steel tubing.

- Steel forged body. Ergonomic handle for a safer handling;
- Steel expander heads to correct distorted tubing with diameter identification on for an easy recognition;
- Steel Adaptor;
- Deburring Tool and Plastic Carrying Case.



Model	Description
THE 618	Hydra Swage Tube Tool Kit (415 Bar) for Ø 3/8", 1/2", 5/8", 3/4", 7/8", 1" and 1-1/8" O.D. tubing. Adapter Deburring tool in Plastic Carrying Case.
THE 628	Kit (693 Bar) for Ø 3/8", 1/2", 5/8", 3/4", 7/8", 1", 1-1/8", 1-3/8", 1-5/8" and 2-1/8" O.D. tubing. Adapter Deburring tool in Plastic Carrying Case.
THE1028MM	Kit (415 Bar) for Ø 10, 12, 15, 16, 18, 22 and 28 mm. O.D. tubing. Adapter Deburring tool in Plastic Carrying Case.
<b>Spare Parts</b>	
THE601	Hydraulic Pump 6.000 Psi (415 Bar) - Body only.
THE602	Hydraulic Pump 10.000 Psi (693 Bar) - Body only.
THE601-D	Adapter for THE 618 and THE1028MM.
THE602-D	Heavy Duty Adapter for THE 628.
THEPB	Plastic Carrying Case.
TEH 6	Expander Head for Ø 3/8" O.D. tubing
TEH 8	Ø 1/2" O.D. tubing
TEH10	Ø 5/8" O.D. tubing
TEH12	Ø 3/4" O.D. tubing
TEH14	Ø 7/8" O.D. tubing
TEH16	Ø 1" O.D. tubing
TEH18	Ø 1-1/8" (28 mm.) O.D. tubing
TEH22	Ø 1-3/8" (35 mm.) O.D. tubing
TEH26	Ø 1-5/8" (42 mm.) O.D. tubing
TEH34	Ø 2-1/8" O.D. tubing
TEH10MM	Expander Head for Ø 10 mm. O.D. tubing
TEH12MM	Ø 12 mm. O.D. tubing
TEH15MM	Ø 15 mm. O.D. tubing
TEH16MM	Ø 16 mm. O.D. tubing
TEH18MM	Ø 18 mm. O.D. tubing
TEH22MM	Ø 22 mm. O.D. tubing